

REV	DESCRIPTION	ECN #	CHG BY	DATE	APP'D
A	UPDATED TOP DESIGN	14751	EZR	11/1/18	MJC
B	UPDATED CLIP TO HEAVY DUTY/NAME FROM CSL	16039	RWK	04/17/19	NAD
C	UPDATED ELEMENT SPECS	17839	TAS	12/04/19	NAD

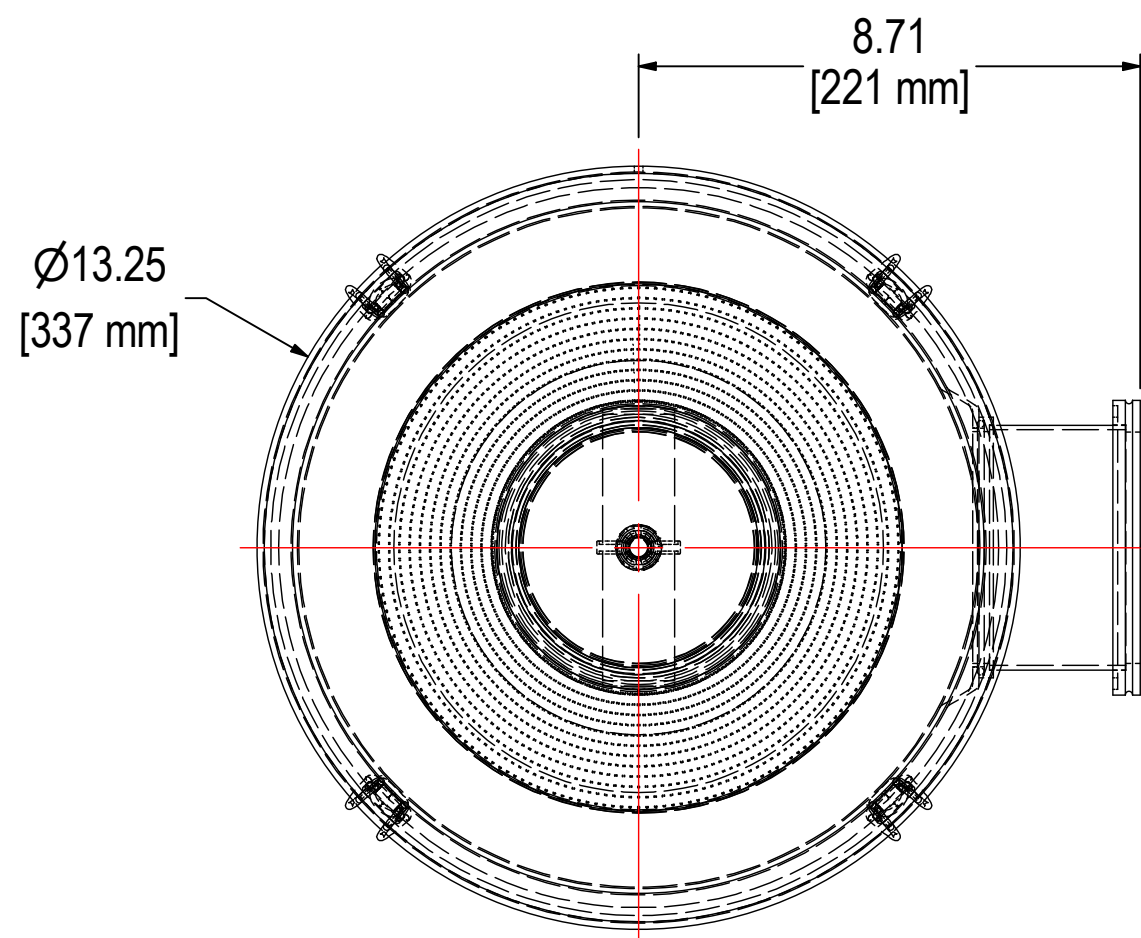

FLANGE FACE SURFACES TO BE FREE OF SCRATCHES, DIVOTS, OR ANY DEFORMATION THAT AFFECTS SEAL. FLANGE FACES TO BE PROTECTED DURING SHIPMENT.

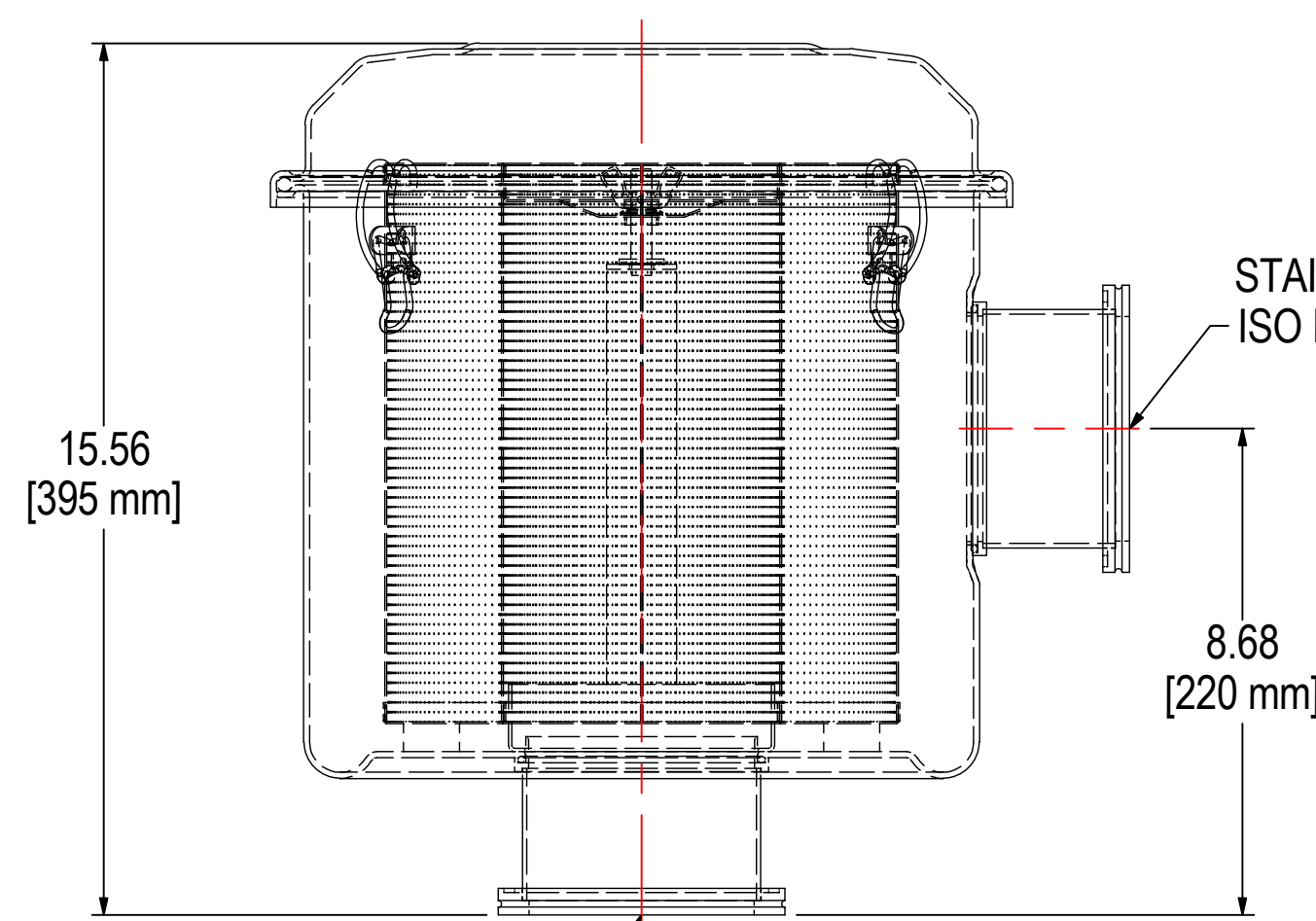

STAINLESS STEEL ISO K 100 FITTING INLET

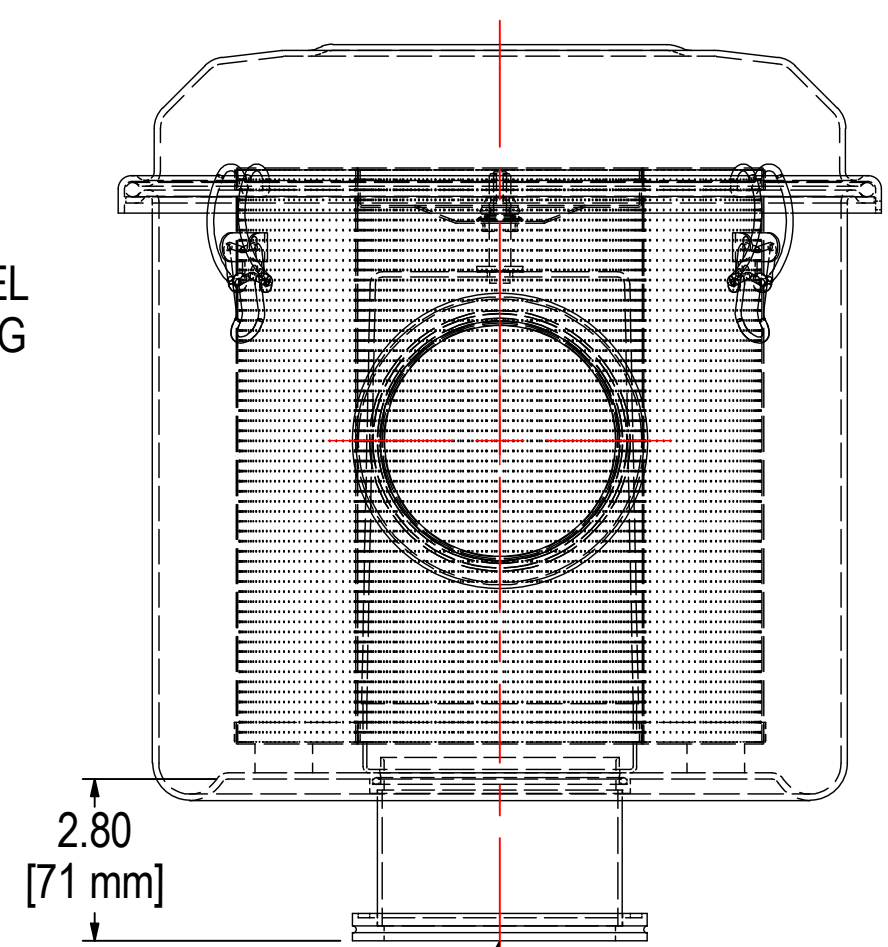

STAINLESS STEEL ISO K 100 FITTING OUTLET

FLANGE FACE SURFACES TO BE FREE OF SCRATCHES, DIVOTS, OR ANY DEFORMATION THAT AFFECTS SEAL. FLANGE FACES TO BE PROTECTED DURING SHIPMENT.

NOTES & SPECIFICATIONS:

1. FLANGES TO BE PROTECTED DURING PRODUCTION & SHIPMENT.
2. UNIT TO BE HELIUM LEAK TESTED TO 1 X 10⁻⁵ mbar L/s.

ELEMENT SPECS		
PART NUMBER	238	
MATERIAL	PAPER	
FLOW RATE	570 CFM	968 m ³ /hr
SURFACE AREA	48.3 ft ²	4.5 m ²
I.D.	4.85"	123mm
O.D.	9.22"	234mm
HEIGHT	10.50"	267mm

MODEL #: WL-238-K100B	MATERIAL: CARBON STEEL	FINISH: BLACK POWDER
MODEL NUMBER: WL-238-K100B	SHEET: 1 OF 1	
DESCRIPTION: WL-238-K100B, BLACK		
PROJECT:	DRAWN BY: EZR	APPROVED BY: NAD
	DATE: 11/27/2017	DATE: 11/27/2017
		REV: C

SOLBERG
Filtration • Separation • Silencing
630.773.1363 • www.solbergmfg.com

THE INFORMATION CONTAINED HEREIN IS CONFIDENTIAL AND THE PROPERTY OF SOLBERG MANUFACTURING INC. AND IT IS FURNISHED TO YOU WITH THE EXPRESS UNDERSTANDING THAT IT WILL NOT BE REPRODUCED, COPIED IN ANY MANNER, LOANED OR OTHERWISE TRANSFERRED TO OTHERS ENTIRELY OR IN PART, NOR USED FOR ANY PURPOSE OTHER THAN FOR WHICH IT WAS FURNISHED. IT WILL BE RETURNED UPON REQUEST TO SOLBERG MANUFACTURING INC. THE ABOVE RESTRICTION IS IN ADDITION TO, AND DOES NOT IN ANY WAY ALTER, ANY OTHER RESTRICTIONS WHICH MAY APPLY TO THE INFORMATION CONTAINED HEREIN.

TOLERANCES
DIMENSIONS ARE FOR REFERENCE ONLY. ALL DIMENSIONS ARE SUBJECT TO CHANGE UPON PRODUCTION.
UNLESS OTHERWISE SPECIFIED:
-DIMENSIONS ARE IN INCHES
-REF: APPROXIMATE DIMENSIONS, NO TOLERANCES APPLY
-FINISH: BREAK EDGES TO .005-.020 RADIUS/CHAMFER